

Carton sealer

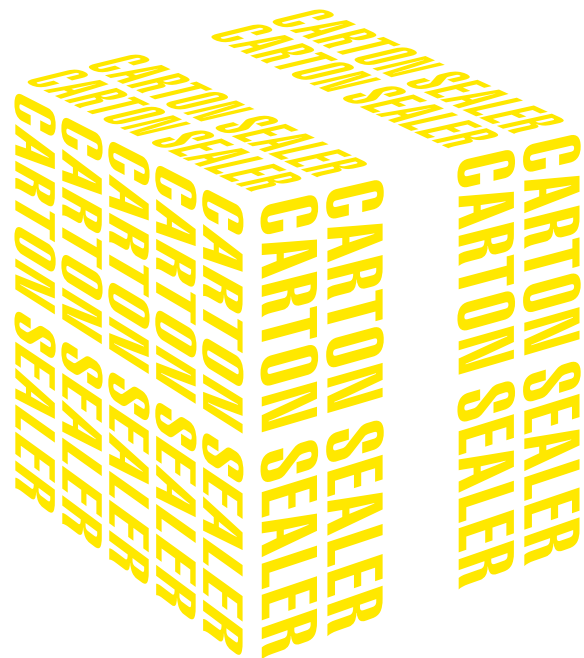

MH-FJ-1 series

MH-FJ-1A Automatic Carton Sealer

- Top & side belts drive
- Suitable for heavy products

Model	MH-FJ-1A
Power supply	1P 110V/220V 50Hz/60Hz 300W/470W
Sealing speed	30cartons/min
Carton size	L(150-∞)×W(120-480)×H(120-480)mm
Tape size	48-72mm (Kraft or BOPP tape)
Machine size	L(1090)×W(890)×H(1280)mm
Shipping size	L(1200)×W(1050)×H(1435)mm
G.W/N.W	250Kg/200Kg
Optional	① Extension roller table ② Feet wheel ③Stainless steel

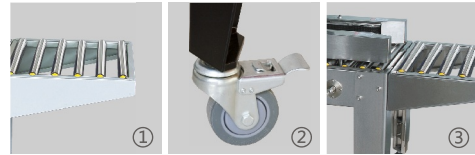

MH-FJ-1A
With Guide
Automatic Carton Sealer

MH-FJ-1AW Automatic Carton Sealer

- Side belts drive
- Suitable for products in light weight

Model	MH-FJ-1AW
Power supply	1P 110V/220V 50Hz/60Hz 200W/400W
Sealing speed	30cartons/min
Carton size	L(150-∞)×W(120-480)×H(120-480)mm
Tape size	48-72mm (Kraft or BOPP tape)
Machine size	L(1090)×W(890)×H(1280)mm
Shipping size	L(1200)×W(1050)×H(1435)mm
G.W/N.W	230Kg/180Kg
Optional	① Extension roller table ② Feet wheel ③Stainless steel

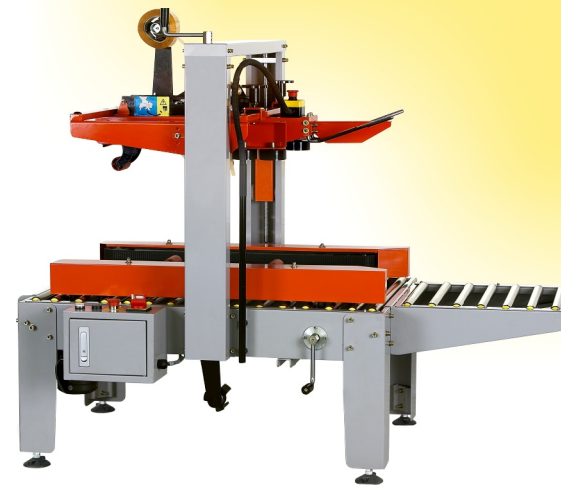
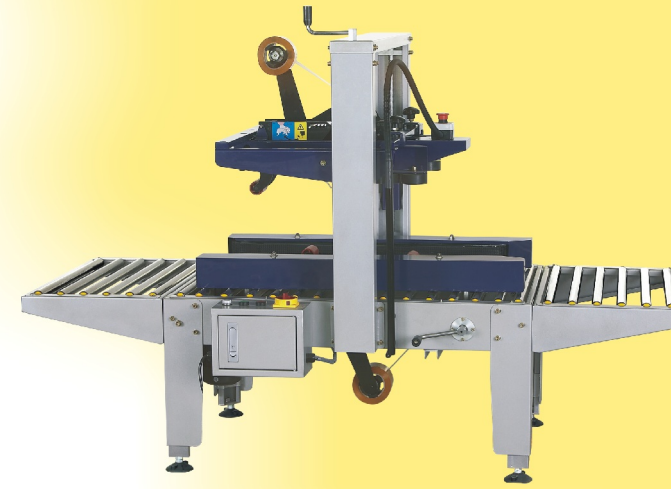

MH-FJ-1AW
With Guide
automatic Carton Sealer

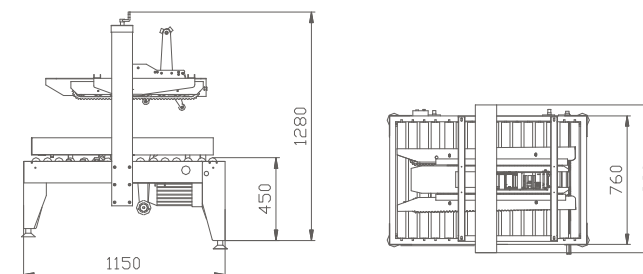
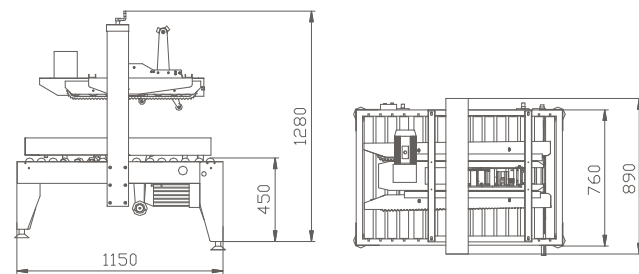

MH-FJ- 1series



MH-FJ-1AWS Smart stainless Steel Carton Sealer

- Side belts drive
- Suitable for products in small box

Model	MH-FJ-1AWS
Power supply	1P 110V/220V 50Hz/60Hz 200W/400W
Sealing speed	30cartons/min
Carton size	L(200-∞)×W(95-300)×H(70-300)mm
Tape size	48mm (Kraft or BOPP tape) folded tape 35mm
Machine size	L(1090)×W(793)×H(1280)mm
Shipping size	L(1150)×W(800)×H(1435)mm
G.W/N.W	230Kg/180Kg
Optional	① Extension roller table ② Feet wheel ③ Not stainless steel

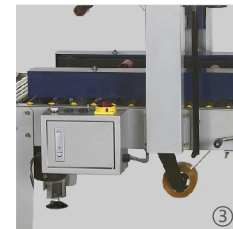

MH-FJ-1D Automatic Carton Sealer

- Top & bottom belts drive
- Suitable for products in light weight

Model	MH-FJ-1D
Power supply	1P 110V/220V 50Hz/60Hz 470W/570W
Sealing speed	30cartons/min
Carton size	L(150-∞)×W(180-500)×H(120-480)mm
Tape size	48-72mm (Kraft or BOPP tape)
Machine size	L(970)×W(890)×H(1280)mm
Shipping size	L(1150)×W(1050)×H(1435)mm
G.W/N.W	240Kg/190Kg
Optional	① Extension roller table ② Feet wheel ③ Not stainless steel

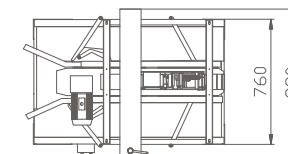
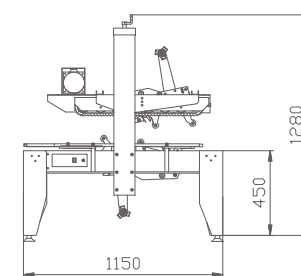
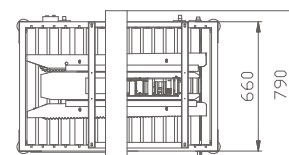
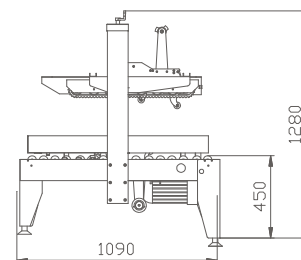
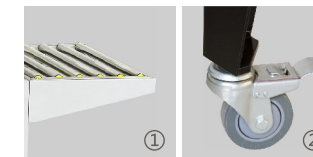

MH-FJ-1 series

MH-FJ-2 series

MH-FJ-1S Automatic Carton Sealer

- Side sealer
- Top & bottom belts drive

Model	MH-FJ-1S
Power supply	1P 110V/220V 50Hz/60Hz 470W/570W
Sealing speed	30cartons/min
Carton size	L(150-∞)×W(190-350)×H(120-480)mm
Tape size	48-72mm (Kraft or BOPP tape)
Machine size	L(968)×W(1090)×H(1280)mm
Shipping size	L(1150)×W(1100)×H(1435)mm
G.W/N.W	245Kg/185Kg
Optional	① Extension roller table ② Feet wheel ③ Stainless steel



MH-FJ-2 Side-band Automatic Carton sealer

- Side belts drive
- Automatically adjust the sealing height and width

Model	MH-FJ-2
Power supply	1P 110V/220V 50Hz/60Hz 200W/400W
Sealing speed	15cartons/min
Carton size	L(150-∞)×W(120-500)×H(120-450)mm
Tape size	48-72mm (Kraft or BOPP tape)
Machine size	L(1150)×W(1005)×H(1230)mm
Shipping size	L(1200)×W(1100)×H(1400)mm
G.W/N.W	300Kg/250Kg
Optional	① Extension roller table ② Feet wheel ③ Guard ④ Stainless steel

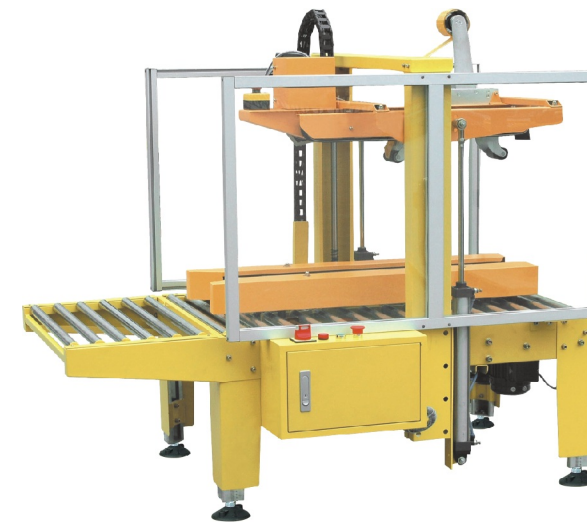

world advanced packing system

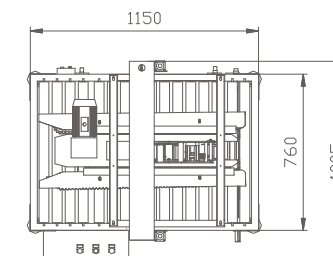
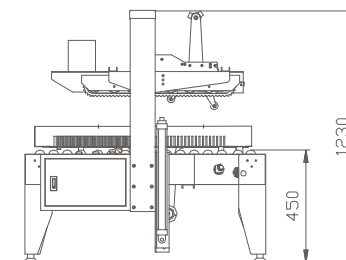
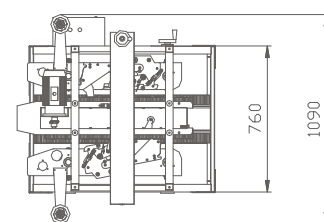
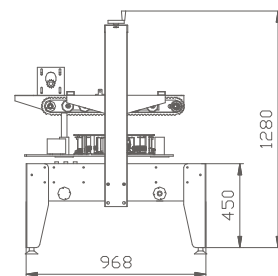

MH-FJ- 2series

MH-FJ-2CF

Pneumatic
Carton Sealer and semi case former

- Side belts drive
- Automatically adjust the sealing width

Model	MH-FJ-2CF
Power supply	1P 110V/220V 50Hz/60Hz 400W
Sealing speed	8 cartons/min
Carton size	L(200-450)×W(200-450)×H(150-480)mm
Tape size	48-72mm (Kraft or BOPP tape)
Machine size	L(2000)×W(1005)×H(1230)mm
Shipping size	L(2200)×W(1100)×H(1400)mm
G.W/N.W	400Kg/350Kg
Optional	① Extension roller table ② Feet wheel ③ Guard ④ Stainless steel

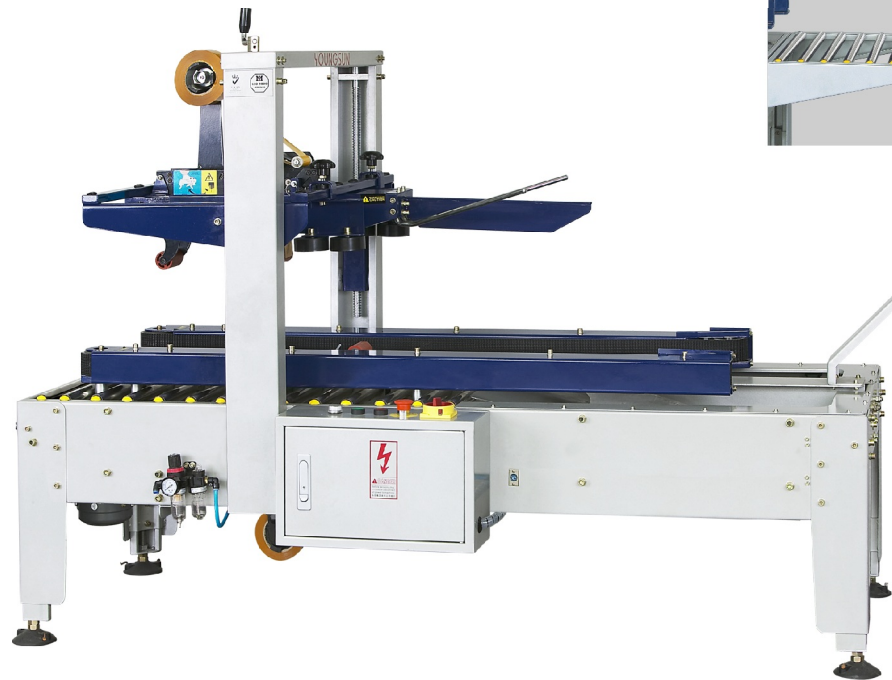

MH-FJ- 3series

MH-FJ-3A

Automatic Carton Sealer

- Side belts drive
- Automatically fold the top flaps

Model	MH-FJ-3A
Power supply	1P 110V/220V 50Hz/60Hz 400W
Sealing speed	12-15cartons/min
Carton size	L(200-550)×W(150-480)×H(127-480)mm
Tape size	48-72mm (Kraft or BOPP tape)
Machine size	L(1850)×W(988)×H(1370)mm
Shipping size	L(2000)×W(1050)×H(1570)mm
G.W/N.W	360Kg/300Kg
Optional	① Feet wheel ② Guard ③Stainless steel

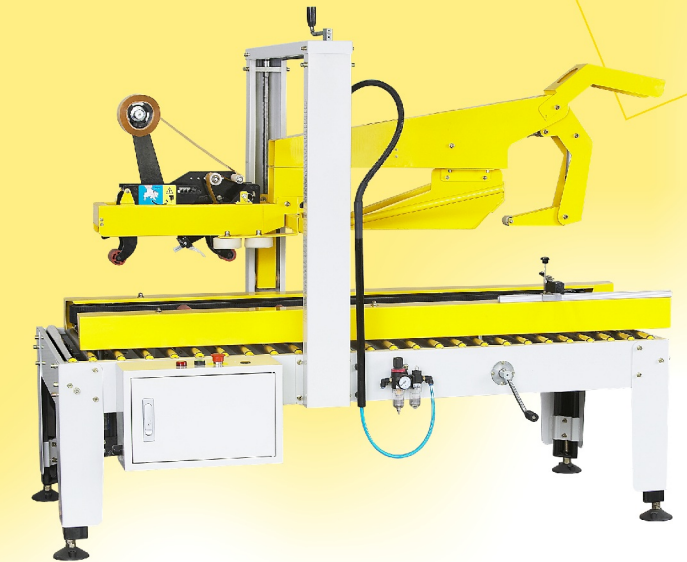

MH-FJ-3A

Stainless Steel
Automatic Carton Sealer

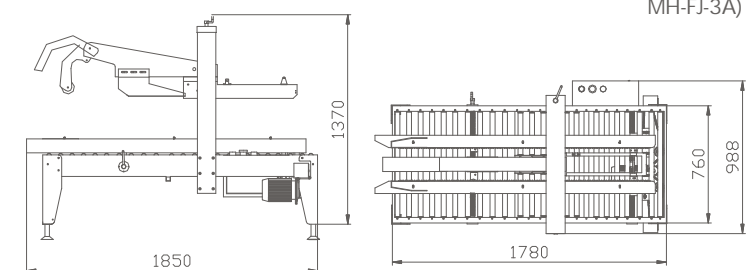

MH-FJ-3A)

MH-FJ-3series

MH-FJ-3A With Guard Automatic Carton Sealer

- Side belts drive
- Automatically fold the top flaps

Model	MH-FJ-3A
Power supply	1P 110V/220V 50Hz/60Hz 400W
Sealing speed	12-15cartons/min
Carton size	L(200-550)×W(150-480)×H(127-480)mm
Tape size	48-72mm (Kraft or BOPP tape)
Machine size	L(1850)×W(988)×H(1370)mm
Shipping size	L(2000)×W(1050)×H(1570)mm
G.W/N.W	360Kg/300Kg
Optional	① Feet wheel

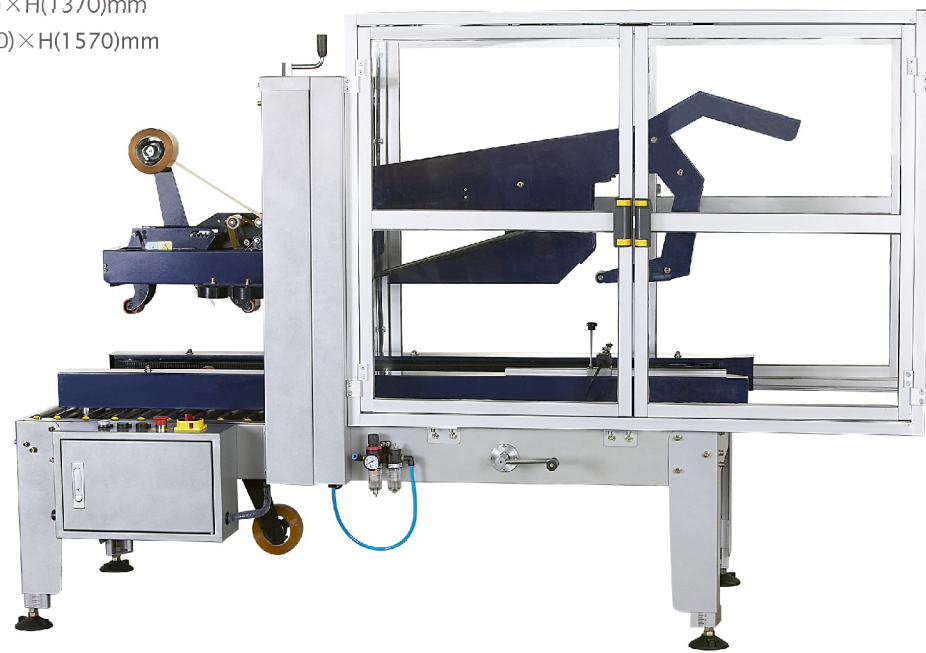
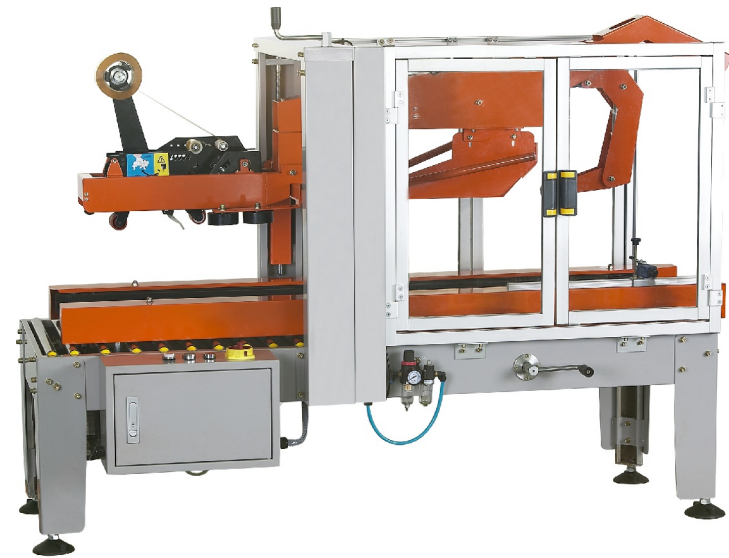

MH-FJ-3B Side-band Automatic Carton sealer

- Automatically fold the top flaps
- Automatically adjust the sealing height and width
- Suitable to connect to the full automatic packaging line

Model	MH-FJ-3B
Power supply	3P 380V 50Hz/60Hz 800W
Sealing speed	12cartons/min
Carton size	L(250-600)×W(180-450)×H(150-450)mm
Tape size	48-72mm (Kraft or BOPP tape)
Machine size	L(2100)×W(1050)×H(1750)mm
Shipping size	L(2150)×W(1100)×H(2000)mm
G.W/N.W	640Kg/550Kg
Optional	① Feet wheel ② Guard ③ Electric control box



world advanced packing system

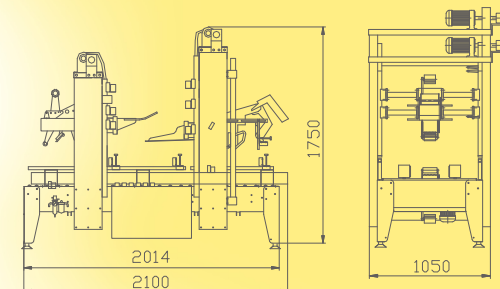
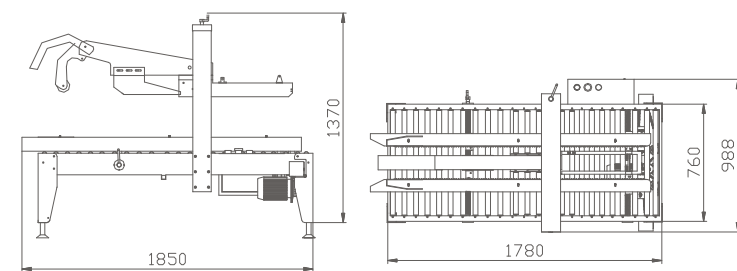

MH-FJ-3C Automatic Carton Sealer

- Suitable for the cartons with extra width, extra height and extra length
- Fold the top of cartons automatically

Model	MH-FJ-3C
Power supply	3P 380V 50Hz/60Hz 1370W
Sealing speed	8-10cartons/min
Tape size	48-72mm (Kraft or BOPP tape)

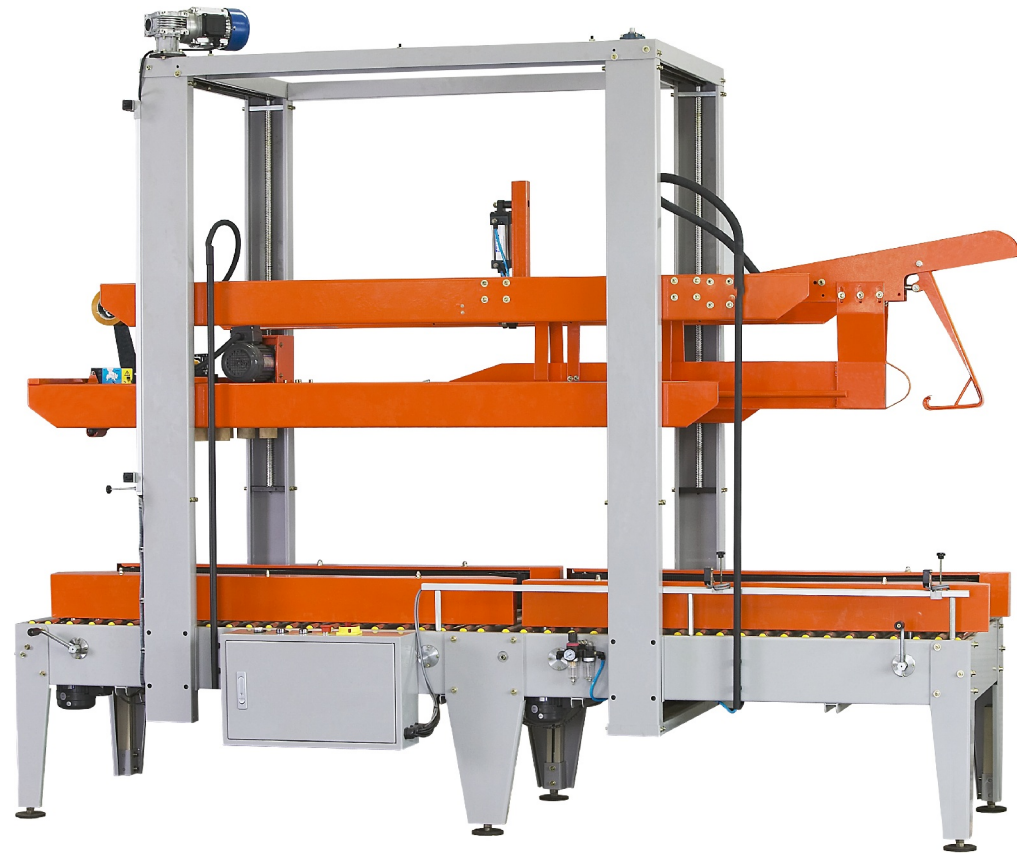

MH-FJ-3D Automatic Carton Sealer

- Suitable for large-sized packages
- With the automatic box nailing machine (Automatic nailing up and down or sealing cartons up and down is optional)
- Fold the top of cartons automatically

Model	MH-FJ-3D
Power supply	3P 380V 50Hz/60Hz 1370W
Sealing speed	8-10cartons/min
Tape size	48-72mm (Kraft or BOPP tape)

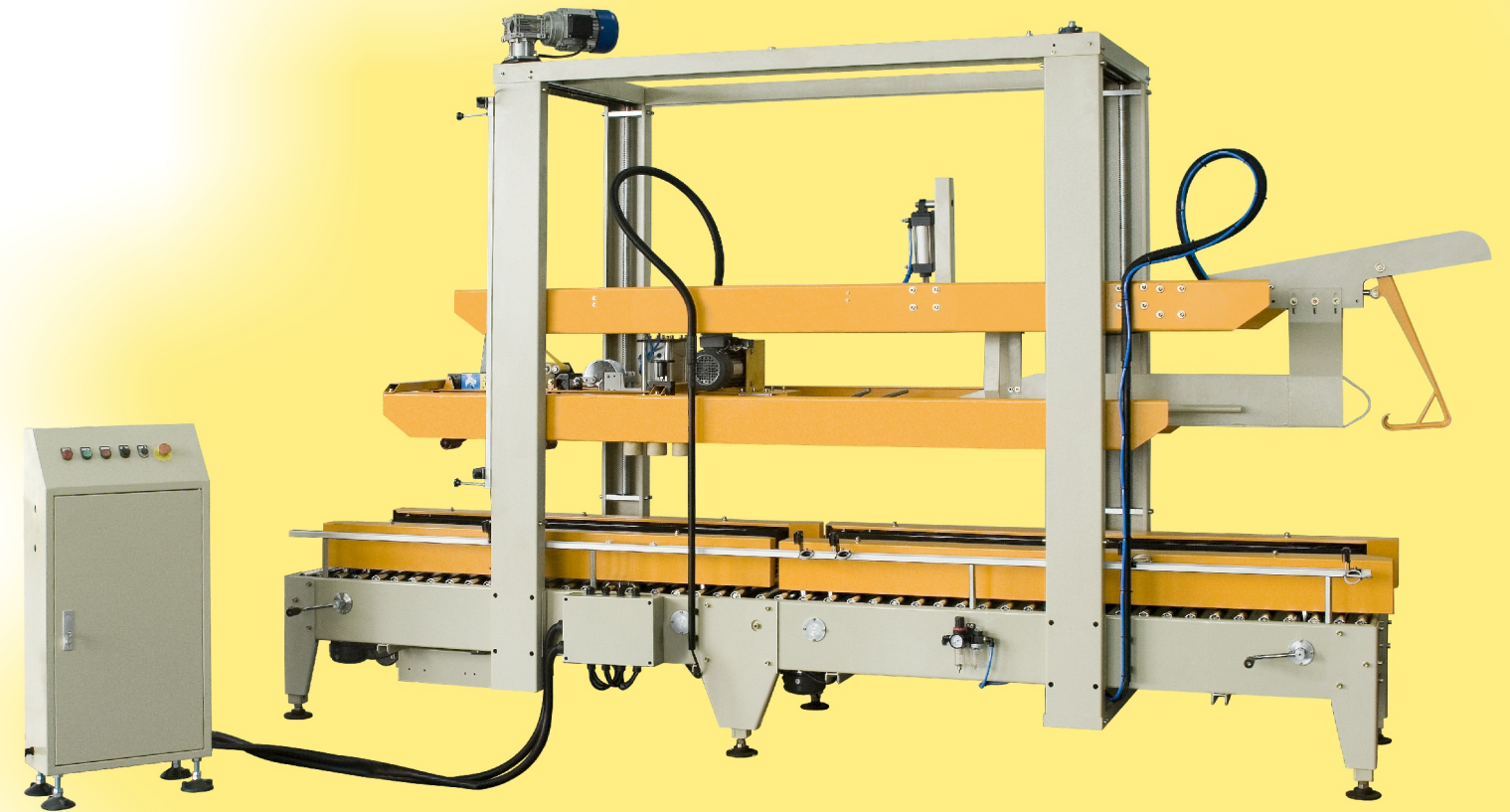

Mini series

MA Mini Automatic Carton Sealer

Model	MA
Power supply	220V 50HZ 200W
Carton size	L 150-∞ W 120-500 H 120-500 mm
Conveying speed (Belt speed)	22 meters/min
Tape type	Kraft paper or BOPP
Adhesive tape size	48mm (48-72mm) optional
Weight	90kg
Worktable height	750mm
Machine size	L 850 x W880 x H 1200mm (the height depends on the carton size)
Optional	① Extension roller table



MD Mini Automatic Carton Sealer

Model	MD
Power supply	220V 50HZ 200W
Carton size	L 150-∞ W 180-450 H 120-500 mm
Conveying speed (Belt speed)	16.7 meters/min
Tape type	Kraft paper or BOPP
Adhesive tape size	48mm (48-72mm) optional
Weight	120kg
Worktable height	750mm
Machine size	L 850 x W780 x H 1270mm (the height depends on the carton size)
Optional	① Extension roller table



MH-FJ-P1 Corner-type Full Automatic Carton Sealer

- Auto sealing top bottom edges
- Manual adjusted carton sizes

Model	MH-FJ-P1
Power supply	1P 110V/220V 50Hz/60Hz 1000W
Sealing speed	12-15cartons/min
Carton size	L(200-500)×W(350-700)×H(200-500)mm
Tape size	48-72mm (Kraft or BOPP tape)
Machine size	L(2200)×W(1280)×H(1400)mm
Shipping size	L(2250)×W(1330)×H(1600)mm
G.W/N.W	550Kg/480Kg
Optional	① Feet wheel ② Guard

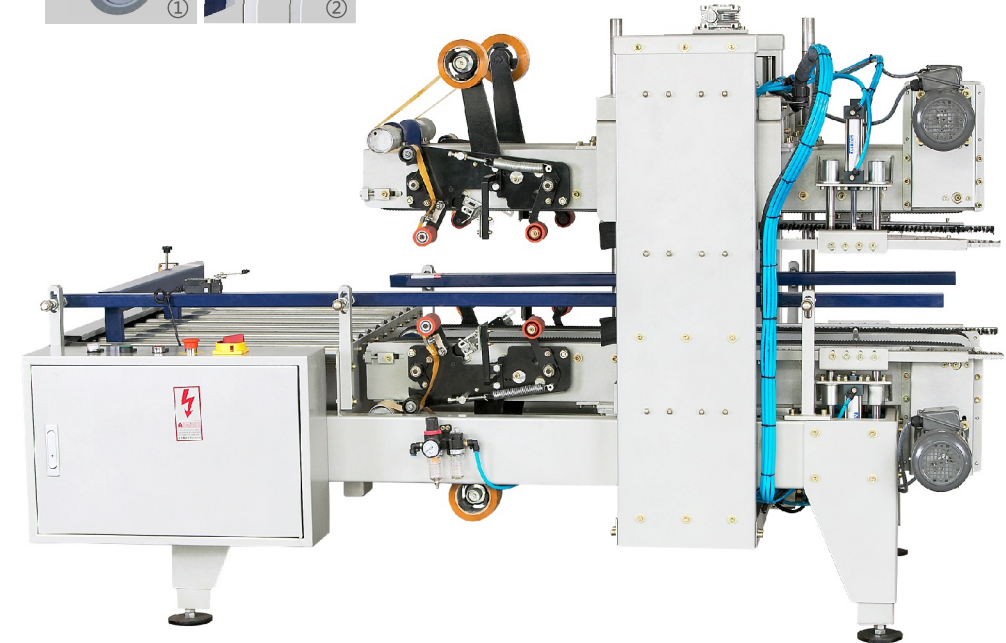
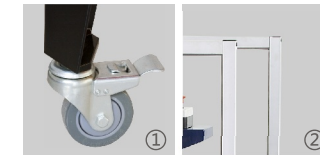

MH-FJ-P1 series



world advanced packing system

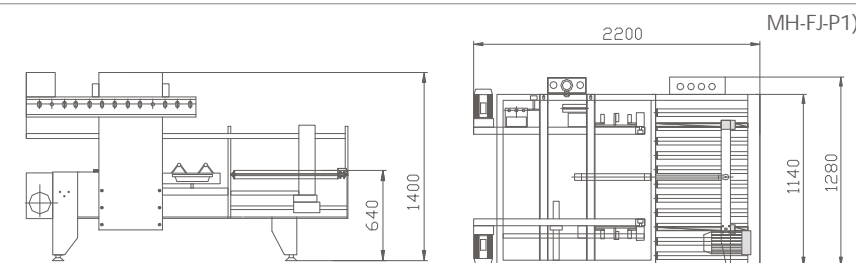

YS-501AW Automatic Carton Sealer

- Side belts drive
- Suitable for products in light weight

Model	YS-501AW
Power supply	1P 110V/220V 50Hz/60Hz 200W
Sealing speed	30cartons/min
Carton size	L(150-∞)×W(120-480)×H(130-480)mm
Tape size	48-72mm (Kraft or BOPP tape)
Machine size	L(1090)×W(880)×H(1165)mm
Shipping size	L(1628)×W(930)×H(1265)mm
G.W/N.W	220Kg/170Kg
Optional	① Extension roller table ② Feet wheel ③ Stainless steel



YS-501D Automatic Carton Sealer

- Top & bottom belts drive
- Suitable products in light weight

Model	YS-501D
Power supply	1P 110V/220V 50Hz/60Hz 200W
Sealing speed	30cartons/min
Carton size	L(150-∞)×W(180-500)×H(120-480)mm
Tape size	48-72mm (Kraft or BOPP tape)
Machine size	L(1150)×W(890)×H(1280)mm
Shipping size	L(1150)×W(1050)×H(1435)mm
G.W/N.W	240Kg/190Kg
Optional	① Extension roller table ② Feet wheel ③ Stainless steel

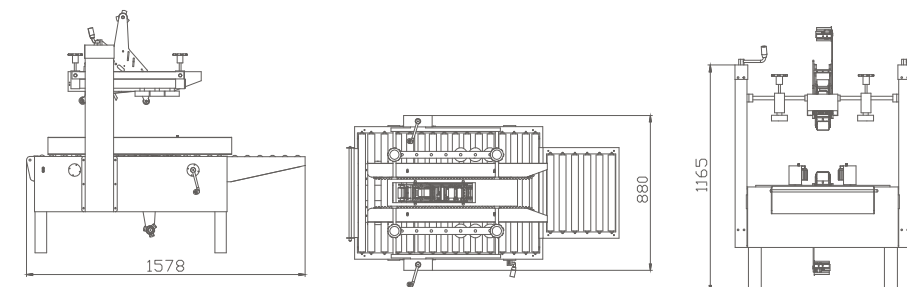
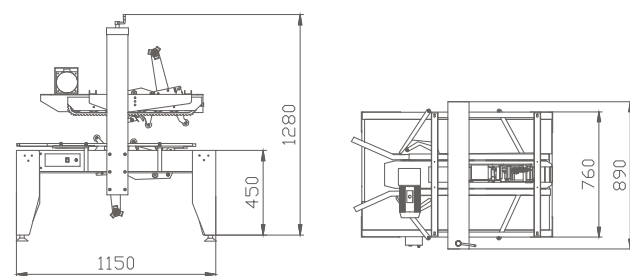

YS-502

Automatic Carton Sealer

YS-502

Stainless Steel
Automatic Carton Sealer

- Side belts drive
- Suitable for products in light weight
- Automatically adjust the sealing height and width

Model	YS-502
Power supply	1P 110V/220V 50Hz/60Hz 400W
Sealing speed	20cartons/min
Carton size	L(150-∞)×W(120-480)×H(130-480)mm
Tape size	48-72mm (Kraft or BOPP tape)
Machine size	L(1154)×W(920)×H(1275)mm
Shipping size	L(1690)×W(970)×H(1425)mm
G.W/N.W	250Kg/300Kg
Optional	① Extension roller table ② Feet wheel ③ Guard

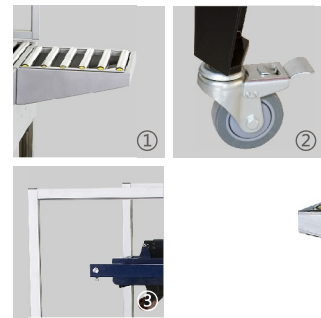

YS-503

Automatic Carton Sealer

- Driven by the top motor and non-bottom sealing
- Suitable for beverage and beer factory packing
- High speed producing
- It can match hot glue machine

Model	YS-503
Power supply	3P 380V 600W
Sealing speed	50cartons/min
Carton size	L(250-450)×W(200-400)×H(250-400)mm
Tape size	48-72mm (Kraft or BOPP tape)
Machine size	L(2000)×W(1100)×H(2000)mm
Table height	750 mm
Optional	① Extension roller table L (500)mm ② Hot melt

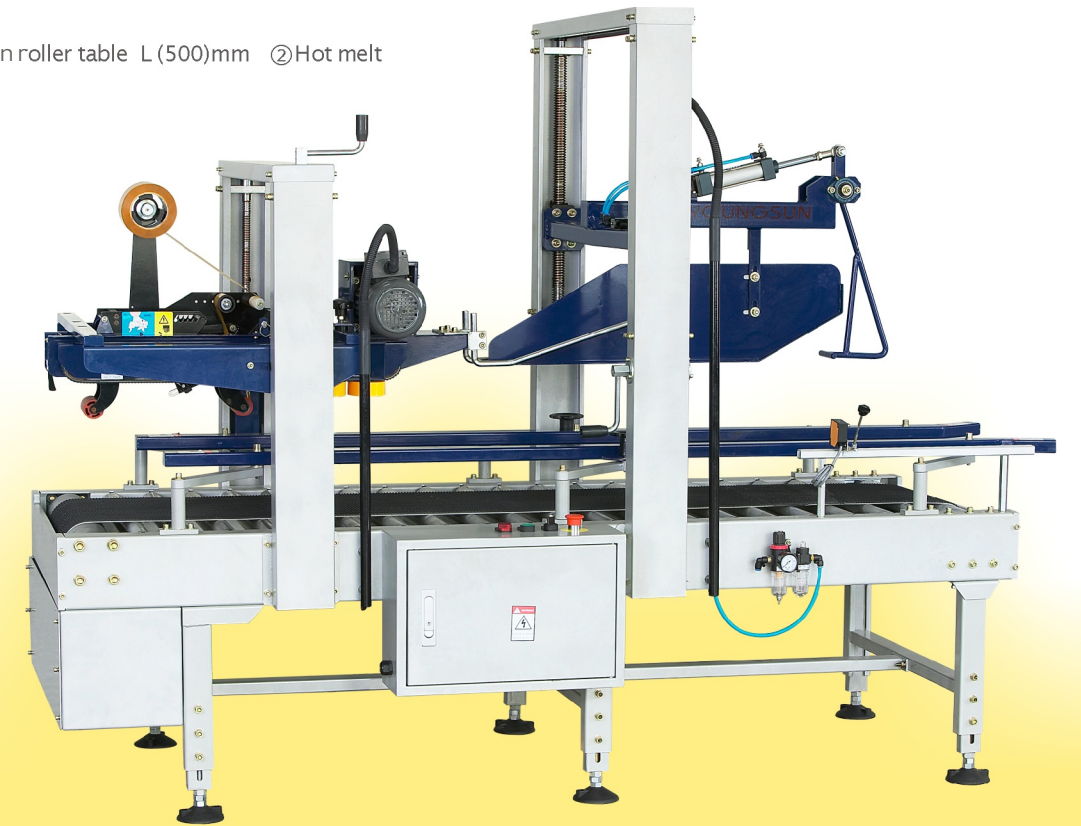

world advanced packing system



TH-1

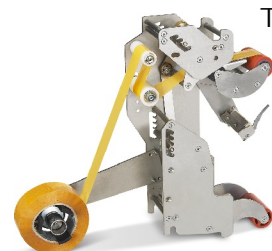

TH-1 Steel



TH-2



TH-3

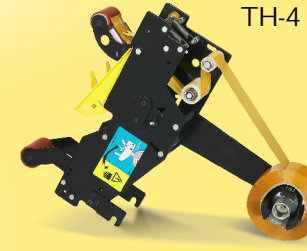

TH-4



TH-5